

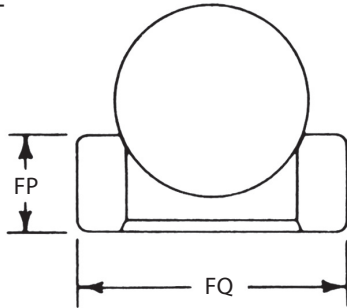

BALL AND SEAT API CHART

FLAT
SEAT



RIB
SEAT

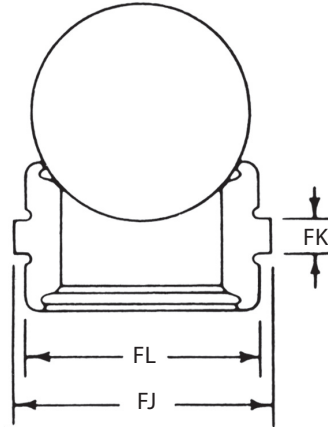

BALL AND SEAT DIMENSIONS

SIZE	API SIZE DESIGNATION	SEAT DIMENSIONS					BALL SIZE	
		FJ	FK	FL	FP	FQ	REG.	ALT.
1"	100F13-F14	.730	.156	.626	—	—	5/8"	9/16"
	100F23-F24	—	—	—	.375	.763	5/8"	9/16"
1-1/16"	106F23-F24	—	—	—	.500	.793	5/8"	9/16"
1-1/4"	125F23-F24	—	—	—	.500	.918	3/4"	11/16"
1-3/8"	NOT API	.968	.216	.875	—	—	7/8"	—
1-1/2"	150F13-F14	1.094	.156	.969	—	—	15/16"	7/8"
	150F23-F24	—	—	—	.500	1.168	15/16"	7/8"
1-5/8"	NOT API	1.125	.216	.988	—	—	7/8"	—
1-3/4"	175F13-F14	1.342	.156	1.188	—	—	1-1/8"	1"
	175F23-F24	—	—	—	.500	1.388	1-1/8"	1"
2"	200F13-F14	1.436	.156	1.281	—	—	1-1/4"	1-1/8"
	200F23-F24	—	—	—	.500	1.478	1-1/4"	1-1/8"
2-1/4"	225F13-F14	1.655	.156	1.438	—	—	1-3/8"	1-1/4"
	225F23-F24	—	—	—	.500	1.720	1-3/8"	1-1/4"
2-3/4"	275F13-F14	1.967	.156	1.751	—	—	1-11/16"	1-1/2"
	275F23-F24	—	—	—	.500	2.010	1-11/16"	1-1/2"
3"	NOT API	2.250	.250	2.000	—	—	2"	—
3-1/8"	NOT API	2.300	.250	2.125	—	—	2"	1-7/8"
3-1/4"	NOT API	2.406	.250	2.250	—	—	2"	1-7/8"
3-1/4"	325F13-F14	2.687	.188	2.250	—	—	2-1/8"	2"
	325F23-F24	—	—	—	.750	2.710	2-1/8"	2"
3-3/4"	375F13-F14	2.905	.188	2.626	—	—	2-1/4"	2"
	375F23-F24	—	—	—	.750	3.072	2-1/4"	2"
4-3/4"	475F13-F14	3.780	.375	3.376	—	—	3-1/4"	—

API TOLERANCES

FJ	+ .000
	- .040
FK	+ .060
	- .000
FL	+ .000
	- .002
FQ	+ .000
	- .005