

SNUBBER CAGES

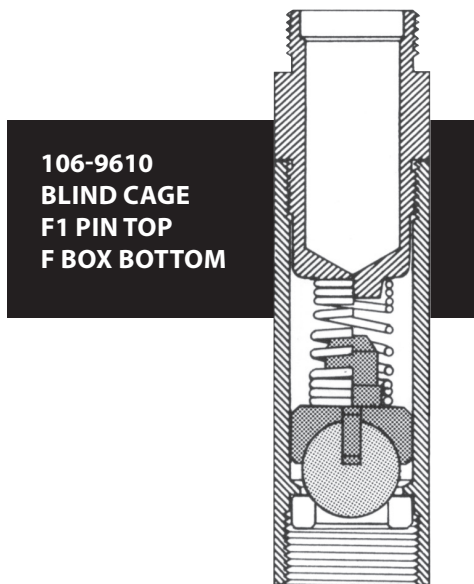

106-9610 BLIND CAGE *FOR BOTTOM DOUBLE VALVE F PIN THREAD TOP*



API SIZE		API SEAT		PART NO. RIB SEAT	PART NO. FLAT SEAT
CAGE	SEAT	RIB	FLAT		
1"	1"	100F12	100F22	106-9610-100-R	106-9610-100-F
1-1/16"	1-1/16"	—	106F22	—	106-9610-106-F
1-1/4"	1-1/4"	—	125F22	—	106-9610-125-F
1-1/2"	1-1/2"	150F12	150F22	106-9610-150-R	106-9610-150-F
1-3/4"	1-3/4"	175F12	175F22	106-9610-175-R	106-9610-175-F
2"	2"	200F12	200F22	106-9610-200-R	106-9610-200-F
X2"	2-1/4"	X200F12	X200F22	106-9610-X200-R	106-9610-X200-F
2-1/4"	2-1/4"	225F12	225F22	106-9610-225-R	106-9610-225-F
2-1/2"	2-1/2"	250F12	250F22	106-9610-250-R	106-9610-250-F
2-3/4"	2-3/4"	275F12	275F22	106-9610-275-R	106-9610-275-F
3-3/4"	3-3/4"	375F12	375F22	106-9610-375-R	106-9610-375-F

**WHEN
ORDERING
CAGES
SPECIFY**

COMPLETE PART NUMBER — Or if not known, refer to Cage Position Chart and Part Number Chart on page 11.

- LIST 9600 SERIES NUMBER
- SIZE OF CAGE OR SEAT (Part Number Chart, page 12 & 13)
- RIB OR FLAT CAGE OR SEAT
- ON THE FOLLOWING CAGES, SPECIFY:
 - 9601 — Pin Size
 - 9604 — G2 Puller To or Plain Top
 - 9622 — Pump Bore