

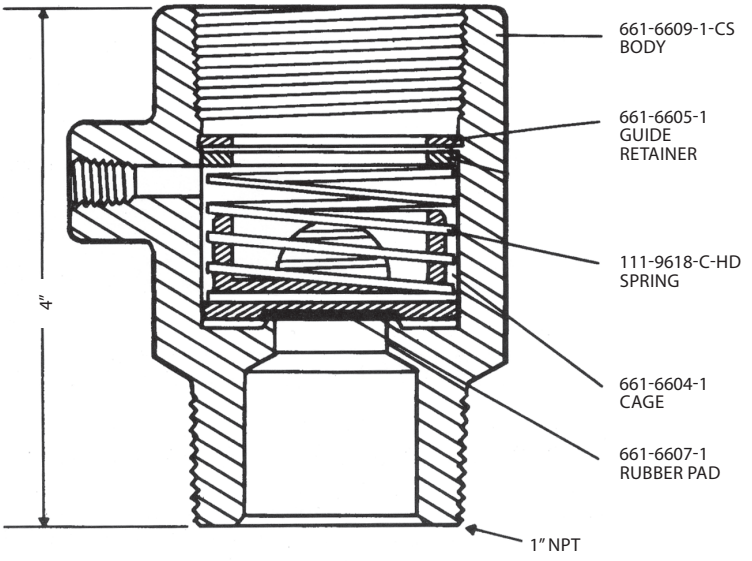

NEW! BAIRD VALVE CHECKER

2" MODEL: 653-2-CS

1" MODEL: 661-1-CS

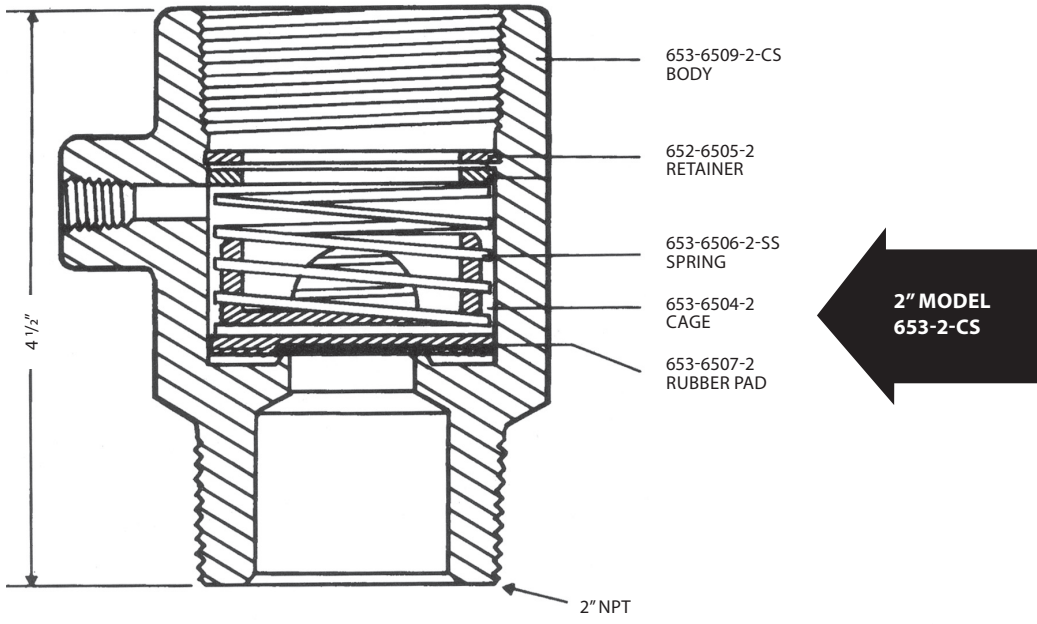

Baird VALVE CHECKER: Installed in front of the safety valve inlet, permits the operator to monitor valves with periodic pressure checks. This gives assurance that the valve is relieving properly at the set pressure, and reclosing as it should.

When using the VALVE CHECKER, the pressure is applied through the 1/4" inlet. The spring-loaded check valve

design insures that the pressure travels only to the valve for the test. When the test is finished, the normal functioning of the manifold returns with flow though the VALVE CHECKER.

The Baird VALVE CHECKER is available in 1" and 2" sizes with standard male by female threads. Other threads are available on request.