



1" GAS VALVE

711-7100-1-G

Pressure: 15-1000#

Volume: to 2731 CFM

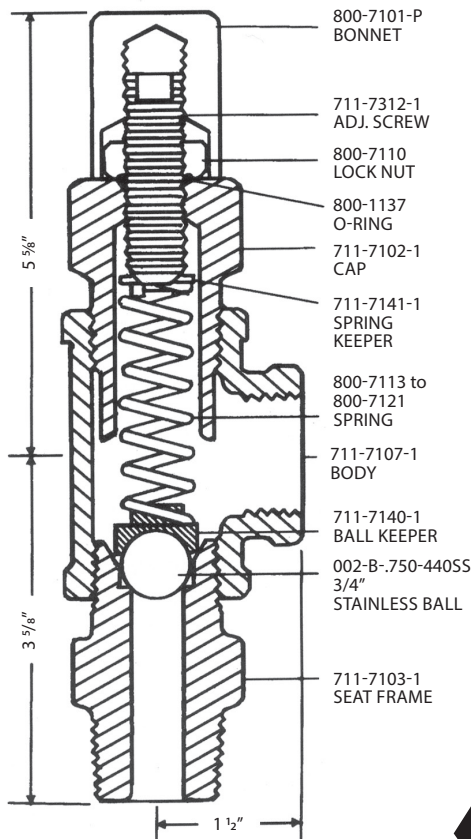

INLETS AVAILABLE: Male NPT 1", 3/4"

OUTLET: Female NPT 1"

INLET ADAPTORS AVAILABLE: Female NPT 1", 3/4", 1/2"

TEMPERATURE RANGE: -65° to +300° F

BODY: (Specify)
 FORGED STEEL — Standard
 316 STAINLESS — Add "316" to Model #

TRIM: Stainless Steel

MANUAL RELEASE LEVER: Optional — Add "H" to Model #

APPLICATION: Recommended for overpressure protection on separators, compressor tanks, heater-treaters, meter runs, gathering lines, transmission systems, gas manifolds, refinery service and other gas systems.



FIELD REPAIRS AND PRESSURE SETTING ADJUSTMENTS ARE EASILY MADE ON-SITE WITHOUT SPECIAL TOOLS.

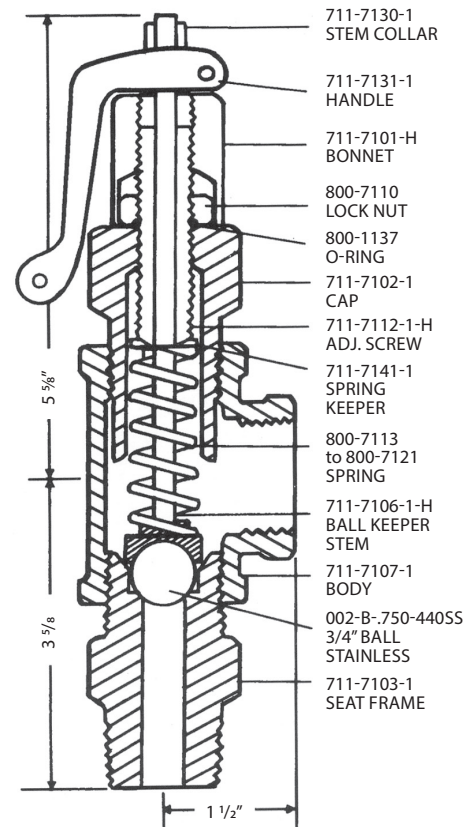

RELIEVING CAPACITIES: 1/2" ORIFICE = .196 SQ. IN., 90% SLOPE = 2.45

FORGED STEEL VALVE PART NUMBER	WORKING PRESSURE RANGE	CFM OF AIR AT MAXIMUM SETTING +10%
711-7100-1-G-25	15 - 25#	25# = 103 CFM
711-7100-1-G-50	25 - 50#	50# = 170 CFM
711-7100-1-G-100	50 - 100#	100# = 305 CFM
711-7100-1-G-200	100 - 200#	200# = 575 CFM
711-7100-1-G-300	200 - 300#	300# = 844 CFM
711-7100-1-G-400	300 - 400#	400# = 1114 CFM
711-7100-1-G-550	400 - 550#	550# = 1518 CFM
711-7100-1-G-700	550 - 700#	700# = 1922 CFM
711-7100-1-G-1000	700 - 1000#	1000# = 2731 CFM